

ES

DESCRIPCIÓN

1. Poli-piel de PVC retardante al fuego. Certificación REACH
2. Martindale 80.000 ciclos
3. Estructura de metal con recubrimiento de pintura en polvo negro
4. Soporte de madera para pica
5. Reposapiés y respaldo eléctricos
6. Mando de control integrado en el lavacabezas
7. Motor: 100-240V /58W / 50-60Hz
8. Espuma de 32 kg de densidad y retardante al fuego

ESTRUCTURA

9. Pica montada sobre mecanismo basculante, orientable vertical y horizontalmente con embellecedor de goma. Válvula con cesta anti-pelos, tapón y tubo de desagüe
10. Kit anti-goteo: Grifo monomando, ducha anti-goteo y flexo (Este kit no está disponible para el mercado italiano)

EN

DESCRIPTION

1. Fire-retardant PVC vinyl. REACH certification
2. Martindale 80.000 cycles
3. Black Powder coated metal structure
4. Wooden basin supporter
5. Electric backrest and footrest
6. Motor control integrated on the shampoo unit
7. Motor: 100-240V /58W / 50-60Hz
8. 32 kg density foam and fire retardant

STRUCTURE

9. Basin mounted on tilting mechanism, adjustable vertically and horizontally with rubber bezel. Valve with anti-hair basket, cap and drain pipe
10. Drop stop kit: Mixer tap, shower head & hose holder and hose. (This kit is not available for the Italian market)

FR

DESCRIPTION

1. Similicuire de PVC retardant au feu. Certification REACH
2. Martindale 80.000 cycles
3. Structure métallique revêtue de poudre noire
4. Support de la céramique en bois
5. Repose-pieds et dossier électriques
6. Commande du moteur intégrée au bac à shampooing
7. Moteur : 100-240V /58W / 50-60Hz8.
8. Mousse à densité 32 kg et retardante au feu

STRUCTURE

9. Céramique monté sur mécanisme de basculement, réglable verticalement et horizontalement avec lunette en caoutchouc. Vanne avec panier anti-cheveux, bouchon et tuyau de vidange
10. Kit aqua-stop: Mitigeur, douchette anti-goutte et flexible (Ce kit n'est pas disponible pour le marché italien)



EMBALAGE · PACKAGING · EMBALLAGE



Cantidad de bultos **2**
Pack quantity
Nombre de paquets A_148x79x77cm
 B_69x65x49cm

COLOR · COLOUR · COULEUR



DETALLES · DETAILS · DÉTAILS



MEDIDAS · MEASUREMENT · MESURE

PESO · WEIGHT · POIDS



147 /
186 cm

wide



90 /
105 cm

height



75 cm

long



net

58,5 Kg

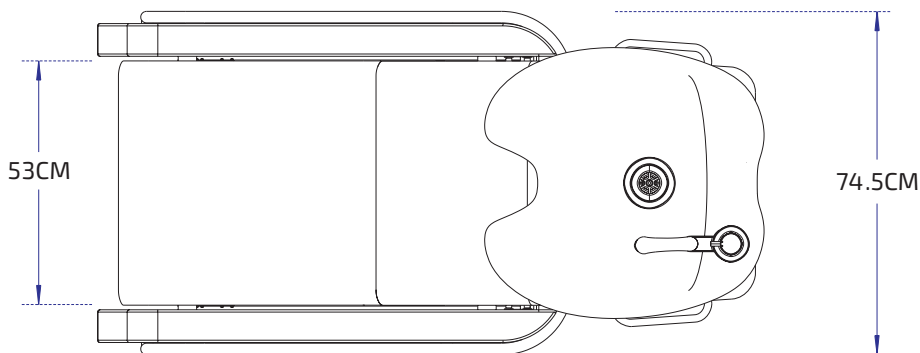
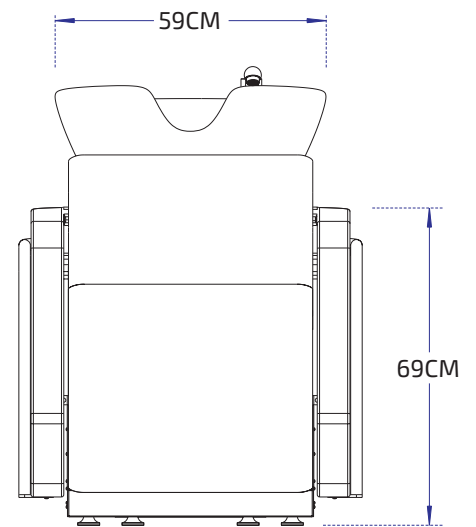
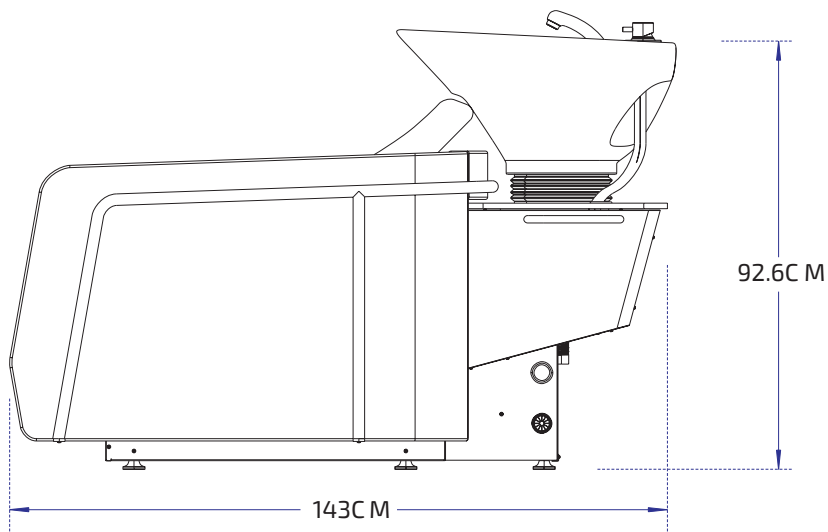
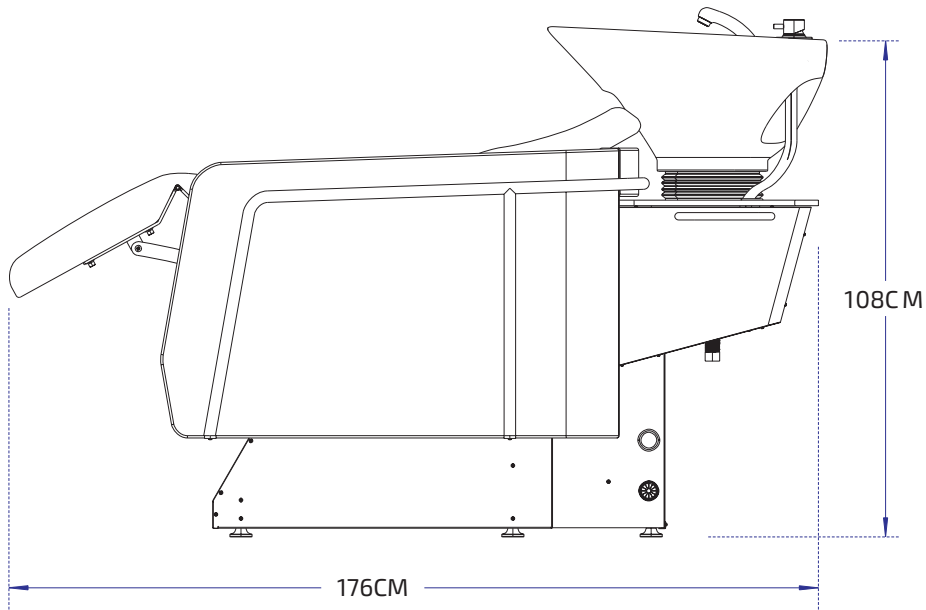

Parte eléctrica / Electrical set / Partie électrique

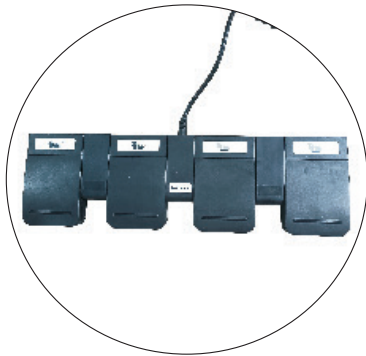

Control de motores con mando integrado en el lavacabezas
 Motor control integrated on the shampoo unit
 Commande des moteurs avec contrôle intégré dans le bac à shampoing

Reclining backrest and basin, ideal for working while seated

Respaldo y cerámica inclinable, ideal para trabajar sentado

Dossier et vasque inclinables, pour travailler assis

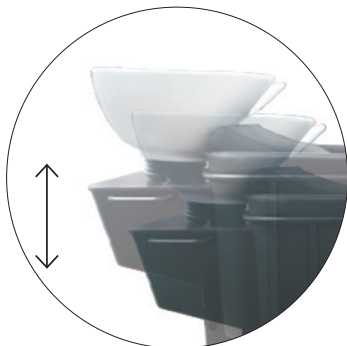
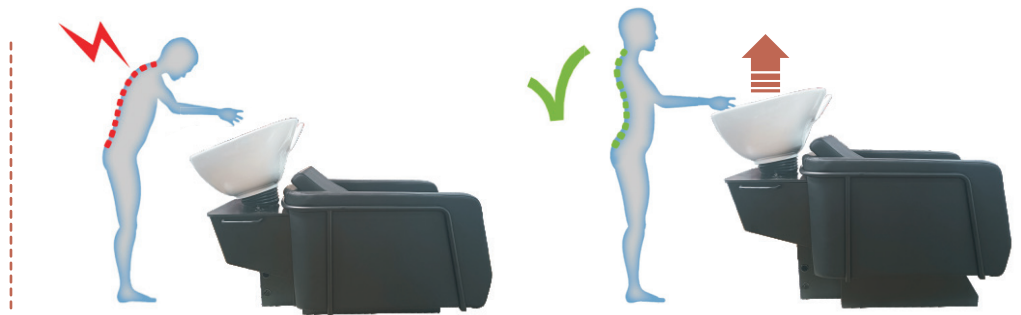

Vertically and horizontally adjustable tilting ceramic basin

Cerámica basculante ajustable vertical y horizontalmente

Vasque basculante ajustable vertical et horizontalement

Voltage: 220-240V
 Button controller Voltage: 220-240V
 Tension 220-240V

Frequencia: 50Hz/60Hz
 Frequency: 50Hz/60Hz
 Fréquence 50Hz/60Hz